

LINK-PIPE[®]

INC.

Manufacturer of No-Dig Pipe Repair Products

27 West Beaver Creek Rd., Unit # 2, Richmond Hill, Ontario
Canada L4B 1M8 Tel: (905) 886-0335 Fax: (905) 886-7323
E-Mail: info@linkpipe.com <http://www.linkpipe.com>

High Pressure Sleeve for Potable Water (For Steel and Plastic Wells - Casings and Screens) Installation Instructions

On-Site storage and handling:

Link-Pipe will supply sleeves in the shipping box. If some damage is observed immediately contact with shipping company and contact with Link-Pipe's engineering personnel for corrective actions.

Equipment:



- Two compressed air Cylinders, with pressure regulator: control valve and gages (See Fig.1 and <http://www.americanairworks.com/index.html>).
- 250 feet (or as long as needed), ¼" 500psi (for this example) hydraulic/air hose to connect the point of repair to above ground air supply.
- Inspection camera.
- Installation Plug with ¼ NPT inlet (**Supplied by Link-Pipe Inc.**). The Customer has to find the inlet converter to metric system locally.
- Winch system for transporting and positioning the sleeve.
- 3 chains (size 5/16") of exactly 6 feet long each.
- 3 chains (size 5/16") of exactly 2 feet long each.
- 12 Safety spring Snap Links which open 5/8".
- Tie Ropes or other to tie gas line to cable when lowering.
- Teflon Tape.

Well Cleaning:

All obstructions protruding from the inner surface of the well casing shall be removed to insure free passing and placement and proper seating of the equipment and the repair sleeve.

Preparation for the Sleeve Installation:

Remove the sleeve from packaging box (See Fig. 2). Carefully remove protection wrapping from the sleeve (Fig.3). **Do not cut or somehow else damage the rubber jacket on the sleeve!!!** Insert the plug into the sleeve (Fig.4) and locate the sleeve in the middle of the plug.

LINK-PIPE and  are registered trademarks of Link-Pipe Inc. in Canada. LINK-PIPE is a registered trademark and  is a trademark of Link-Pipe Inc. in the United States. Dia-Meter[™], Gas Sealer[™], Hydro-Seal[™], Insta-Liner[™], Grouting Sleeve[™], Link-Pipe PVC[™], Pressure-Seal[™], Sewer Sealer[™] and Sewer Sealer VD[™] are trademarks of Link-Pipe Inc. Grouting Sleeve[™] is protected by US Patent No. 5,351,720, Canadian Patent No. 2,131,291, Hong Kong Patent No. HK1003143. Gas Sealer[™] is protected by US Patent No. 6,138,718. Jacketed Sealer[™] is protected by US Patent No. 9,052,051, Russian Patent No. 2533604, Chinese Patent No. ZL201010153141.9, Hong Kong Patent No. HK1149066.

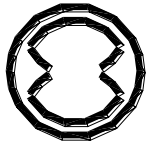

LINK-PIPE[®]

INC.



27 West Beaver Creek Rd., Unit # 2, Richmond Hill, Ontario
Canada L4B 1M8 Tel: (905) 886-0335 Fax: (905) 886-7323
E-Mail: info@linkpipe.com <http://www.linkpipe.com>

Manufacturer of No-Dig Pipe Repair Products

Installation Procedure:

To install the sleeve:

1. Hang the sleeve vertically (Installation sketch Fig. 7).
2. In case a gas will be used to inflate the plug, attach the sinker to the bottom of the plug (Figs. 5 and 7).
3. In case an inspection of locks is intended before the Plug is removed from the well
 - a. Make sure all ropes are in place as shown in the attached sketch Fig. 7.
 - i. 3 Ropes (a), 1m long each, are attached to joints (A) and (C). (C) are the loops of the three black tape Hangers.
 - ii. 3 Chains (c), 2m feet long, are attached to the Plug and joint (B)
 - iii. Cable (b) is attached to joint (B) and extends all the way to the top of the Well.
 - b. Attach gas supply Hose to the Plug.
 - c. Pay special attention to the movement of the Sleeve as it travels in the well casing. Keep the movement slow to make the controls easier. Clean the well casing of all sharp edges in order to avoid ripping the gasket.
 - d. Place the Sleeve within +/- 1 inch from the center of the damage.
 - e. Apply the required air pressure which equals the static water pressure at the installation level (for instance, 15psi) + Installation pressure 80psi. Thus the reading of the located on the ground level pressure gage will be 95psi.
 - f. Allow 1-2 minutes for the Plug pressure to lock the Sleeve and then **slowly** relieve the pressure. If the sleeve is observed to contract away from the casing wall as the Plug pressure is lowered, this is a sign that locking is not complete. Immediately apply the pressure again at 20psi higher than before.
 - g. When the Sleeve is seen remaining tight against the casing wall, the inspection of the lock can commence (Fig. 6).
 - h. Before removing the Plug, lower it to expose Sleeve Locks to the view by the Camera.
 - i. If all locks are not engaged, move the Plug back into the Sleeve and increase the installation pressure by 20psi. It is essential that at least 2 locks at the ends of the Sleeve be engaged.
 - j. When the sleeve is locked in place fully deflate the plug, lower it up to 3 PVC tapes will be detached from the sleeve. Now, pull the plug up.

LINK-PIPE and  are registered trademarks of Link-Pipe Inc. in Canada. LINK-PIPE is a registered trademark and  is a trademark of Link-Pipe Inc. in the United States. Dia-Meter[™], Gas Sealer[™], Hydro-Seal[™], Insta-Liner[™], Grouting Sleeve[™], Link-Pipe PVC[™], Pressure-Seal[™], Sewer Sealer[™] and Sewer Sealer VD[™] are trademarks of Link-Pipe Inc. Grouting Sleeve[™] is protected by US Patent No. 5,351,720, Canadian Patent No. 2,131,291, Hong Kong Patent No. HK1003143. Gas Sealer[™] is protected by US Patent No. 6,138,718. Jacketed Sealer[™] is protected by US Patent No. 9,052,051, Russian Patent No. 2533604, Chinese Patent No. ZL201010153141.9, Hong Kong Patent No. HK1149066.

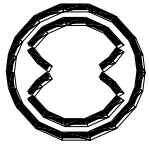

LINK-PIPE[®]

Manufacturer of No-Dig Pipe Repair Products

27 West Beaver Creek Rd., Unit # 2, Richmond Hill, Ontario
Canada L4B 1M8 Tel: (905) 886-0335 Fax: (905) 886-7323
E-Mail: info@linkpipe.com http://www.linkpipe.com



Fig. 1



Fig. 2



Fig. 3





Fig. 4

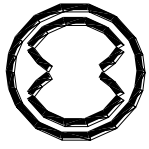

Fig. 5



Fig. 6

LINK-PIPE and  are registered trademarks of Link-Pipe Inc. in Canada. LINK-PIPE is a registered trademark and  is a trademark of Link-Pipe Inc. in the United States. Dia-Meter[™], Gas Sealer[™], Hydro-Seal[™], Insta-Liner[™], Grouting Sleeve[™], Link-Pipe PVC[™], Pressure-Seal[™], Sewer Sealer[™] and Sewer Sealer VD[™] are trademarks of Link-Pipe Inc. Grouting Sleeve[™] is protected by US Patent No. 5,351,720, Canadian Patent No. 2,131,291, Hong Kong Patent No. HK1003143. Gas Sealer[™] is protected by US Patent No. 6,138,718. Jacketed Sealer[™] is protected by US Patent No. 9,052,051, Russian Patent No. 2533604, Chinese Patent No. ZL201010153141.9, Hong Kong Patent No. HK1149066.



LINK-PIPE[®]

INC.

Manufacturer of No-Dig Pipe Repair Products

27 West Beaver Creek Rd., Unit # 2, Richmond Hill, Ontario
Canada L4B 1M8 Tel: (905) 886-0335 Fax: (905) 886-7323
E-Mail: info@linkpipe.com http://www.linkpipe.com

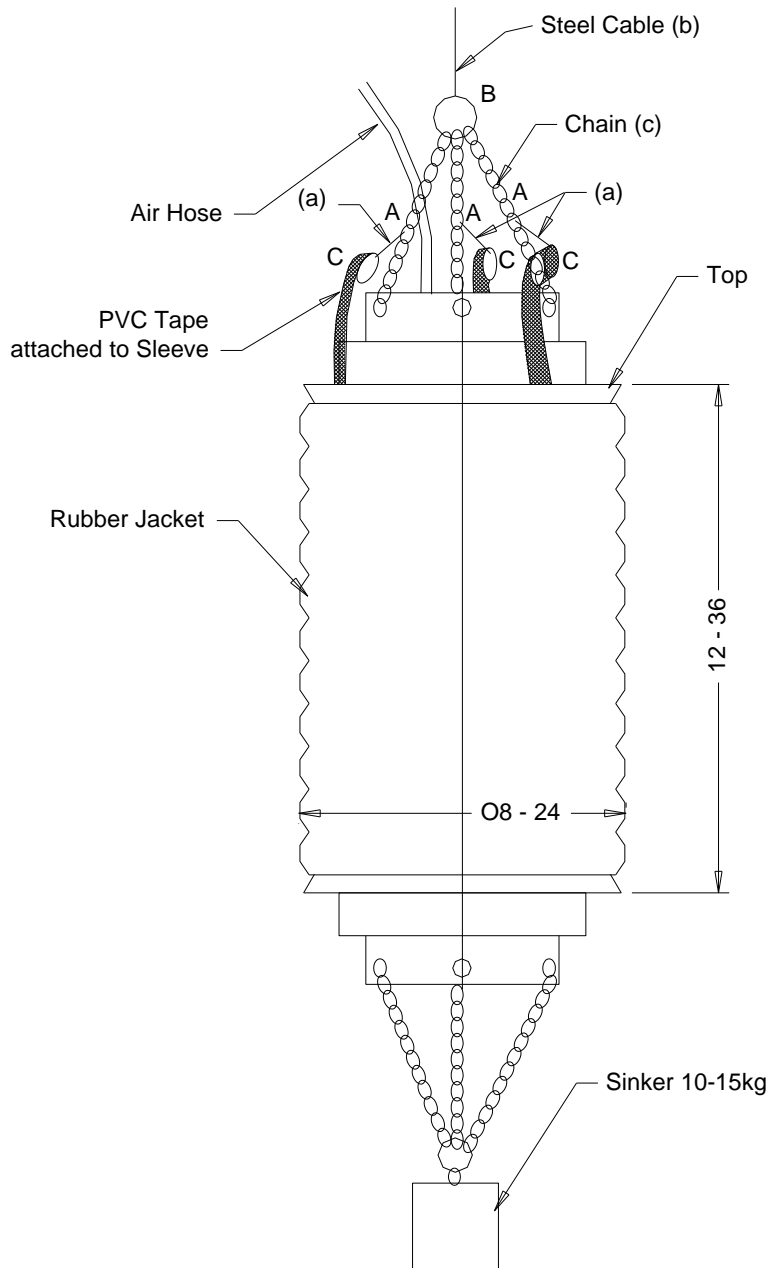



Fig. 7

LINK-PIPE and  are registered trademarks of Link-Pipe Inc. in Canada. LINK-PIPE is a registered trademark and  is a trademark of Link-Pipe Inc. in the United States. Dia-Meter[™], Gas Sealer[™], Hydro-Seal[™], Insta-Liner[™], Grouting Sleeve[™], Link-Pipe PVC[™], Pressure-Seal[™], Sewer Sealer[™] and Sewer Sealer VD[™] are trademarks of Link-Pipe Inc. Grouting Sleeve[™] is protected by US Patent No. 5,351,720, Canadian Patent No. 2,131,291, Hong Kong Patent No. HK1003143. Gas Sealer[™] is protected by US Patent No. 6,138,718. Jacketed Sealer[™] is protected by US Patent No. 9,052,051, Russian Patent No. 2533604, Chinese Patent No. ZL201010153141.9, Hong Kong Patent No. HK1149066.